

SB22FL-AT THRU SB220FL-AT

SURFACE MOUNT SCHOTTKY BARRIER RECTIFIERS

Forward Current-2.0A

Reverse Voltage-20V to 200V

FEATURES

- ◆ For surface mount applications
- ◆ High forward surge current capability
- ◆ Low power loss,high efficiency
- ◆ Metal silicon junction,majority carriers conduction

MECHANICAL DATA

- ◆ Case: SOD-123FL molded plastic body
- ◆ Terminals: Solderable per MIL-STD-750 , Method 2026
- ◆ Weight: Approximated 0.015 grams

PINNING

PIN	DESCRIPTION
1	Cathode
2	Anode

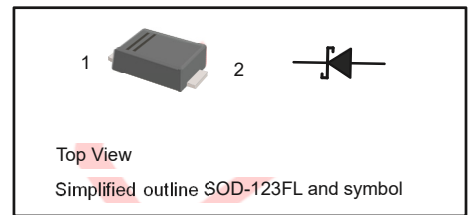

MAXIMUM RATINGS AND ELECTRICAL CHARACTERISTICS

Ratings at 25°C ambient temperature unless otherwise specified.

Single phase half-wave 60 Hz, resistive or inductive load, for capacitive load current derating by 20 %.

PARAMETER	SYMBOL	SB22FL -AT	SB24FL -AT	SB26FL -AT	SB28FL -AT	SB210FL -AT	SB212FL -AT	SB215FL -AT	SB220FL -AT	UNIT
Maximum Repetitive Peak Reverse Voltage	V_{RRM}	20	40	60	80	100	120	150	200	V
Maximum RMS Voltage	V_{RMS}	14	28	42	56	70	84	105	140	V
Maximum DC Blocking Voltage	V_{DC}	20	40	60	80	100	120	150	200	V
Maximum Average Forward Rectified Current at $T_C=85^\circ\text{C}$	$I_{F(AV)}$	2.0								A
Peak Forward Surge Current (Note1)	I_{FSM}	50				40				A
Maximum Forward Voltage at 2.0 A	V_F	0.55		0.70		0.85		0.95		V
Maximum DC Reverse Current at Rated DC Blocking Voltage at $T_A=25^\circ\text{C}$ $T_A=100^\circ\text{C}$	I_R	0.5 5			0.3 3				mA	
Typical Junction Capacitance (Note2)	C_J	220		80						pF
Typical Thermal Resistance (Note3)	$R_{\theta JA}$	85								$^\circ\text{C/W}$
Operating and Storage Temperature Range	T_J, T_{STG}	-55 to +150								$^\circ\text{C}$

Notes: 1. Measured at 8.3 ms single half sine wave superimposed on rated load (JEDEC Method).

2. Measured at 1MHz and applied reverse voltage of 4 V D.C.

3. P.C.B. mounted with 2.0" X 2.0" (5 X 5 cm) copper pad areas.

Dated: 06/2016

Rev:1.0

SB22FL-AT THRU SB220FL-AT

RATINGS AND CHARACTERISTIC CURVES

Fig.1 Forward Current Derating Curve

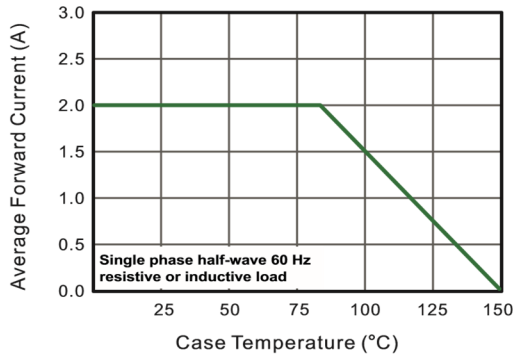

Fig.2 Typical Reverse Characteristics

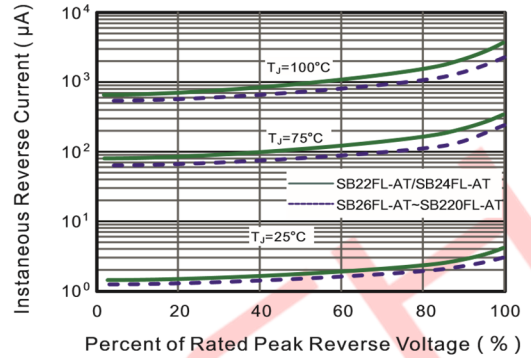

Fig.3 Typical Forward Characteristics

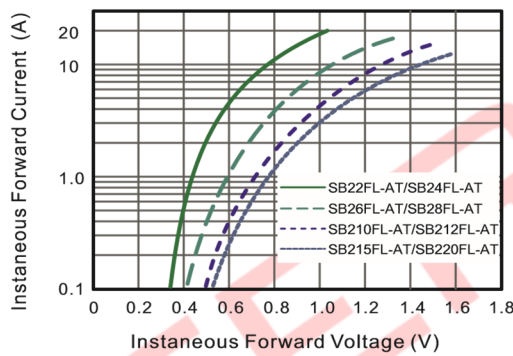

Fig.4 Typical Junction Capacitance

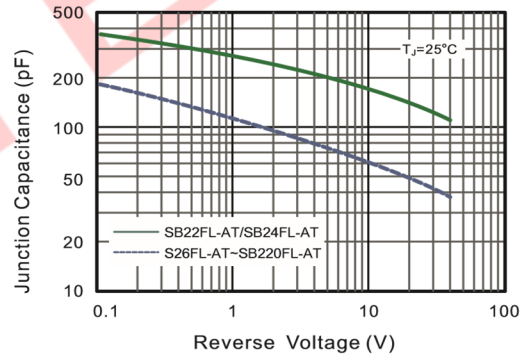

Fig.5 Maximum Non-Repetitive Peak Forward Surge Current

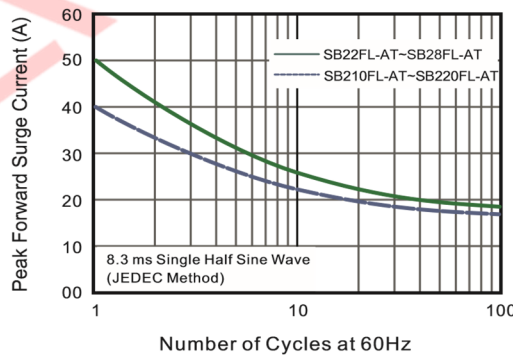
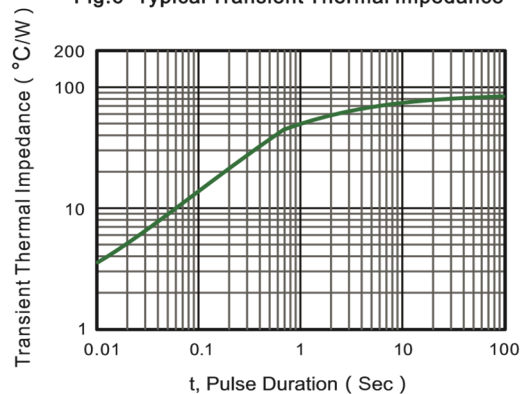

Fig.6- Typical Transient Thermal Impedance



SB22FL-AT THRU SB220FL-AT

PACKAGE OUTLINE

SOD-123FL

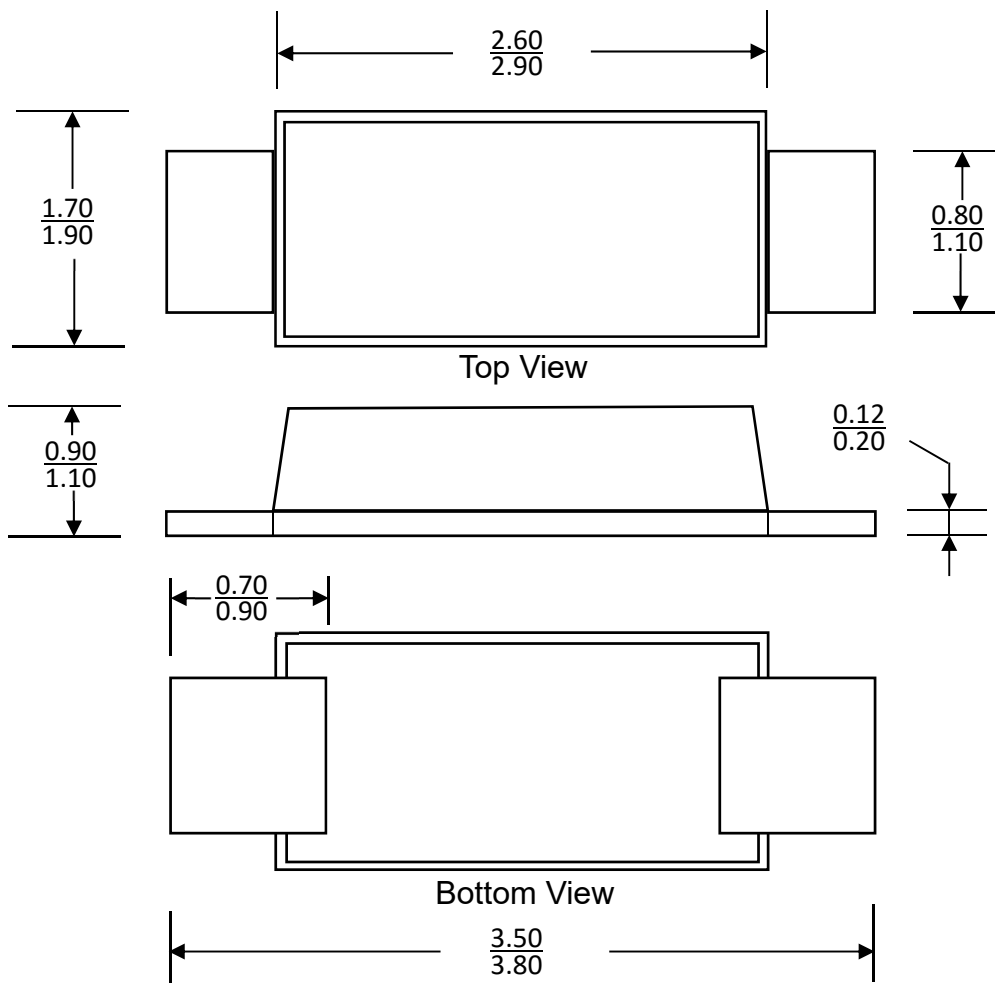

Dimensions in millimeters

ORDERING INFORMATION

Device	Package	Shipping
SB22FL-AT thru SB220FL-AT	SOD-123FL	3,000/Tape & Reel (7 inches)

Dated: 06/2016
Rev:1.0