

SOT-363 Power Management MOSFETs-Schottky

CJ7203KDW N-channel MOSFET and Schottky Barrier Diode

| $V_{(BR)DS}/V_R$ | $R_{DS(on)MAX}$ | I_D/I_o |
|------------------|-----------------|-----------|
| 60V | 5Ω@10V | 340mA |
| | 5.3Ω@5V | |
| 40V | / | 350mA |

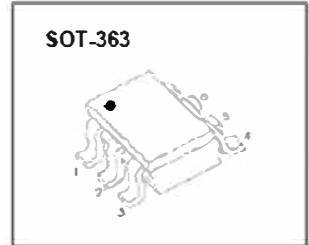

FEATURE

- High density cell design for Low $R_{DS(on)}$
- High saturation current capability
- Low Forward Voltage Drop
- Guard Ring Construction for Transient Protection
- Negligible Reverse Recovery Time
- Low Capacitance

APPLICATION

- Load Switch for Portable Devices
- DC/DC Converter

MARKING



Equivalent Circuit

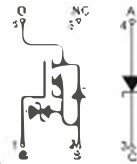

MAXIMUM RATINGS ($T_a=25^\circ\text{C}$ unless otherwise noted)

| Symbol | Parameter | Value | Unit |
|--|--|----------|--------------------|
| N-MOSFET | | | |
| V_{DS} | Drain-Source Voltage | 60 | V |
| V_{GS} | Gate-Source Voltage | ±20 | V |
| I_D | Continuous Drain Current | 0.34 | A |
| I_{DM}^* | Pulse Drain Current | 1.36 | A |
| Schottky Barrier Diode | | | |
| V_{RRM} | Peak Repetitive Reverse Voltage | 40 | V |
| V_R | DC Blocking Voltage | 40 | V |
| I_o | Average Rectified Forward Current | 0.35 | A |
| Power Dissipation, Temperature and Thermal Resistance | | | |
| P_D | Power Dissipation | 0.15 | W |
| $R_{\theta JA}$ | Thermal Resistance from Junction to Ambient | 833 | $^\circ\text{C/W}$ |
| T_J | Junction Temperature | 150 | $^\circ\text{C}$ |
| T_{STG} | Storage Temperature | -55~+150 | $^\circ\text{C}$ |
| T_L | Lead Temperature for Soldering Purposes(1/8" from case for 10 s) | 260 | $^\circ\text{C}$ |

*Repetitive rating: Pulse width limited by junction temperature.

MOSFET ELECTRICAL CHARACTERISTICS

$T_a=25^\circ\text{C}$ unless otherwise specified

| Parameter | Symbol | Test Condition | Min | Typ | Max | Units |
|------------------------------------|--------------|--|------------|-----|-----------|----------|
| N-MOSFET | | | | | | |
| Static Characteristics | | | | | | |
| Drain-Source Breakdown Voltage | V_{DS} | $V_{GS} = 0V, I_D = 250\mu A$ | 60 | | | V |
| Gate Threshold Voltage* | $V_{GS(th)}$ | $V_{DS} = V_{GS}, I_D = 1mA$ | 1 | | 2.5 | V |
| Zero Gate Voltage Drain Current | I_{DSS} | $V_{DS} = 48V, V_{GS} = 0V$ | | | 1 | μA |
| Gate -Source leakage current | I_{SS1} | $V_{GS} = \pm 20V, V_{DS} = 0V$ | | | ± 10 | μA |
| | I_{SS2} | $V_{GS} = \pm 10V, V_{DS} = 0V$ | | | ± 200 | nA |
| | I_{SS3} | $V_{GS} = \pm 5V, V_{DS} = 0V$ | | | ± 100 | nA |
| Drain-Source On-Resistance* | $R_{DS(on)}$ | $V_{GS} = 4.5V, I_D = 200mA$ | | | 5.3 | Ω |
| | | $V_{GS} = 10V, I_D = 500mA$ | | | 5 | Ω |
| Diode Forward Voltage | V_{SD} | $V_{GS} = 0V, I_S = 300mA$ | | | 1.5 | V |
| Recovered charge | Q_r | $V_{GS} = 0V, I_S = 300mA, V_{RK} = 25V, di/dt = -100A/\mu S$ | | 30 | | nC |
| Dynamic Characteristics** | | | | | | |
| Input Capacitance | C_{iss} | $V_{DS} = 10V, V_{GS} = 0V, f = 1MHz$ | | | 40 | pF |
| Output Capacitance | C_{oss} | | | | 30 | pF |
| Reverse Transfer Capacitance | C_{rss} | | | | 10 | pF |
| Switching Characteristics** | | | | | | |
| Turn-On Delay Time | $t_{d(on)}$ | $V_{GS} = 10V, V_{DD} = 50V, R_G = 50\Omega, R_{DS} = 50\Omega, R_L = 250\Omega$ | | | 10 | ns |
| Turn-Off Delay Time | $t_{d(off)}$ | | | | 15 | ns |
| Reverse recovery Time | t_{rr} | $V_{GS} = 0V, I_S = 300mA, V_{RK} = 25V, di/dt = -100A/\mu S$ | | 30 | | ns |
| GATE-SOURCE ZENER DIODE | | | | | | |
| Gate-Source Breakdown Voltage | BV_{GSO} | $I_{GS} = \pm 1mA$ (Open Drain) | ± 21.5 | | ± 30 | V |
| SCHOTTKY BARRIER DIODE | | | | | | |
| Reverse voltage | $V_{(BR)}$ | $I_R = 100\mu A$ | 40 | | | V |
| Reverse current | I_R | $V_R = 30V$ | | | 5 | μA |
| Forward voltage | V_F | $I_F = 20mA$ | | | 0.37 | V |
| | | $I_F = 200mA$ | | | 0.8 | |
| Total capacitance | C_{tot} | $V_R = 0V, f = 1MHz$ | | 50 | | pF |
| Reverse recovery time | t_{rr} | $I_F = I_R = 200mA, I_{FR} = 0.1 \times I_R, R_L = 100\Omega$ | | 10 | | ns |

Notes :

*Pulse Test : Pulse Width $\leq 300\mu s$, Duty Cycle $\leq 2\%$.

**These parameters have no way to verify.

Typical Characteristics

N-channel Characteristics

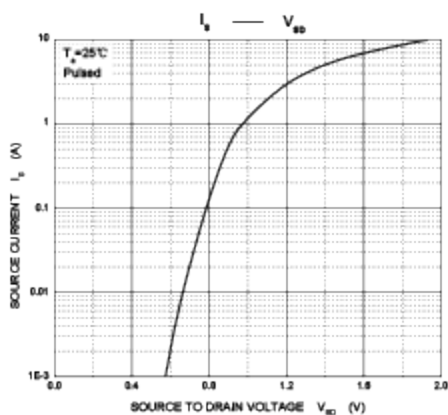
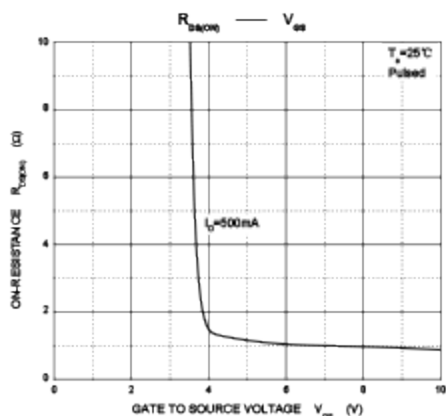
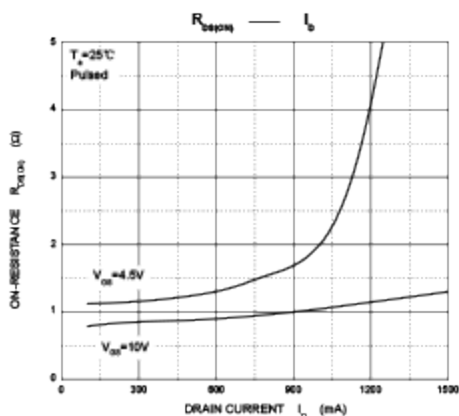
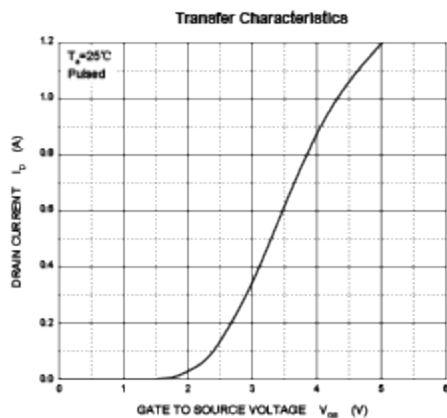
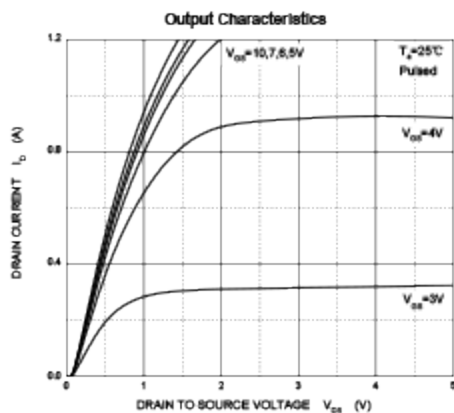

Typical Characteristics

Schottky Characteristics

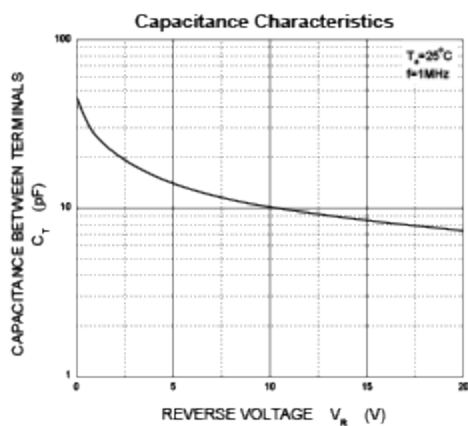
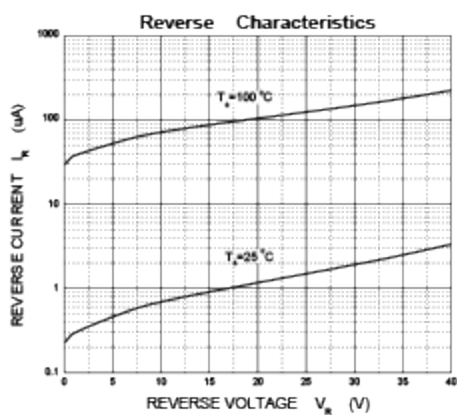
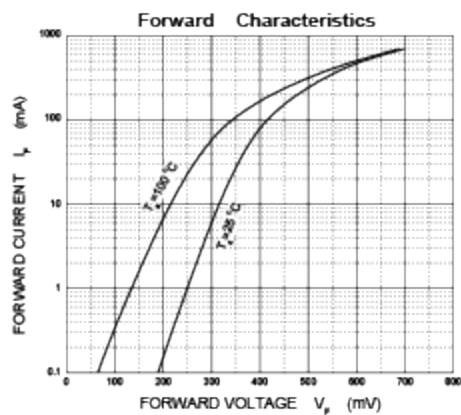

SOT-363 Package Outline Dimensions

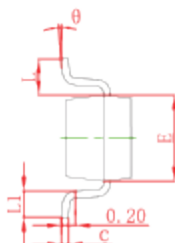
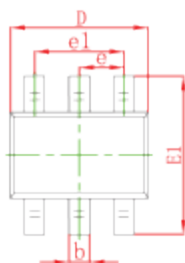

| Symbol | Dimensions in Millimeters | | Dimensions in Inches | |
|--------|---------------------------|-------|----------------------|-------|
| | Min | Max | Min | Max |
| A | 0.900 | 1.300 | 0.035 | 0.043 |
| A1 | 0.000 | 0.700 | 0.000 | 0.004 |
| A2 | 0.900 | 1.000 | 0.035 | 0.039 |
| b | 0.150 | 0.350 | 0.006 | 0.014 |
| c | 0.080 | 0.150 | 0.003 | 0.006 |
| D | 2.000 | 2.200 | 0.079 | 0.087 |
| E | 1.150 | 1.350 | 0.045 | 0.053 |
| E1 | 2.150 | 2.450 | 0.085 | 0.096 |
| e | 0.650 TYP | | 0.026 TYP | |
| e1 | 1.200 | 1.400 | 0.047 | 0.055 |
| L | 0.525 REF | | 0.021 REF | |
| L1 | 0.260 | 0.460 | 0.010 | 0.018 |
| theta | 0° | 8° | 0° | 8° |

SOT-363 Suggested Pad Layout

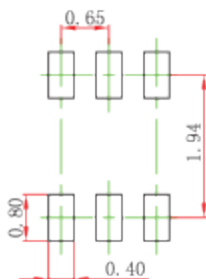

Note:

1. Controlling dimension in millimeters.
2. General tolerance: $\pm 0.05\text{mm}$.
3. The pad layout is for reference purposes only.

NOTICE

JCET reserve the right to make modifications, enhancements, improvements, corrections or other changes without further notice to any product herein. JCET does not assume any liability arising out of the application or use of any product described herein.

SOT-363 Tape and Reel

SOT-363 Embossed Carrier Tape

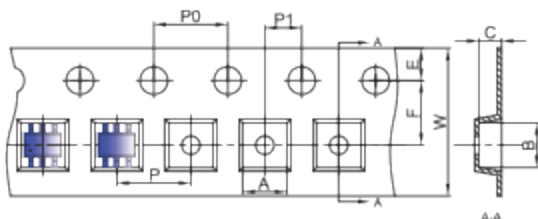

Packaging Description:

SOT-363 parts are shipped in tape. The carrier tape is made from a dissipative (carbon filled) polycarbonate resin. The cover tape is a multilayer film (Heat Activated Adhesive in nature) primarily composed of polyester film, adhesive layer, sealant, and anti-static sprayed agent. These reeled parts in standard option are shipped with 3,000 units per 7" or 17.8cm diameter reel. The reels are clear in color and is made of polystyrene plastic (anti-static coated).

Dimensions are in millimeter

| Pkg type | A | B | C | d | E | F | P0 | P | P1 | W |
|-------------|---------|---------|---------|--------|--------|--------|--------|--------|--------|-----------|
| SOT-363 | 2.25 | 2.55 | 1.20 | Ø1.50 | 1.75 | 3.50 | 4.00 | 4.00 | 2.00 | 8.00 |
| (Tolerance) | +/-0.05 | +/-0.05 | +/-0.05 | +/-0.1 | +/-0.1 | +/-0.1 | +/-0.1 | +/-0.1 | +/-0.1 | +0.3/-0.1 |

SOT-363 Tape Leader and Trailer

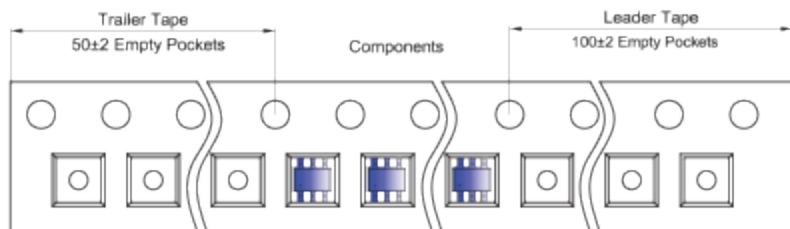

SOT-363 Reel

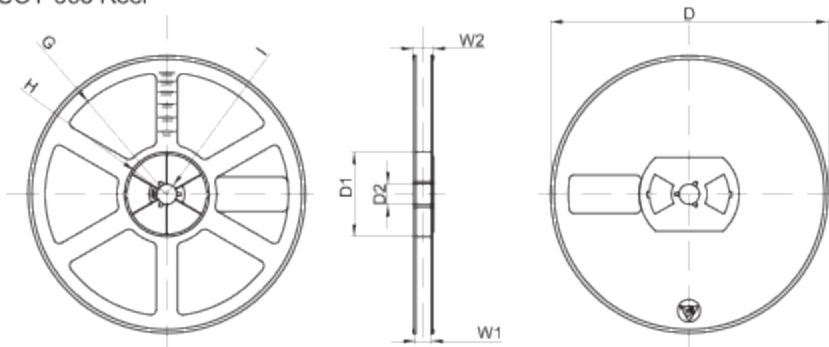

Dimensions are in millimeter

| Reel Option | D | D1 | D2 | G | H | I | W1 | W2 |
|-------------|---------|-------|-------|--------|--------|-------|------|-------|
| 7" Dia | Ø178.00 | 54.40 | 13.00 | R78.00 | R25.60 | R6.50 | 9.50 | 12.30 |
| Tolerance | +/-2 | +/-1 | +/-1 | +/-1 | +/-1 | +/-1 | +/-1 | +/-1 |

| REEL | Reel Size | Box | Box Size(mm) | Carton | Carton Size(mm) | G.W.(kg) |
|----------|-----------|------------|--------------|-------------|-----------------|----------|
| 3000 pcs | 7 inch | 45,000 pcs | 203×203×195 | 180,000 pcs | 438×438×220 | |