

## SOT-23 Encapsulate Adjustable Reference Source

### CJ431 Adjustable Accurate Reference Source

#### DEVICE DESCRIPTION

The CJ431 is a three-terminal adjustable shunt regulator offering excellent temperature stability. This device has a typical dynamic output impedance of  $0.2\Omega$ . The device can be used as a replacement for zener diodes in many applications.

#### FEATURES

- The output voltage can be adjusted to 36V
- Low dynamic output impedance, its typical value is  $0.2\Omega$
- Trapping current capability is 1 to 100mA
- Low output noise voltage
- Fast on-state response
- The effective temperature compensation in the working range of full temperature
- The typical value of the equivalent temperature factor in the whole temperature scope is  $50 \text{ ppm}/^\circ\text{C}$

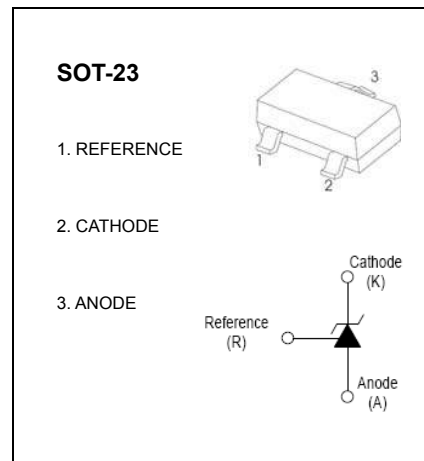

#### APPLICATION

- Shunt Regulator
- High-Current Shunt Regulator
- Precision Current Limiter

#### ABSOLUTE MAXIMUM RATINGS (Operating temperature range applies unless otherwise specified)

Parameter	Symbol	Value	Unit
Cathode Voltage	$V_{KA}$	37	V
Cathode Current Range (Continuous)	$I_{KA}$	-100~+150	mA
Reference Input Current Range	$I_{ref}$	0.05~+10	mA
Power Dissipation	$P_D$	300	mW
Thermal Resistance from Junction to Ambient	$R_{\theta JA}$	417	$^\circ\text{C}/\text{W}$
Operating Junction Temperature	$T_j$	150	$^\circ\text{C}$
Operating Ambient Temperature Range	$T_{opr}$	0~+70	$^\circ\text{C}$
Storage temperature Range	$T_{stg}$	-65~+150	$^\circ\text{C}$

**ELECTRICAL CHARACTERISTICS (T<sub>a</sub>=25°C unless otherwise specified)**

Parameter	Symbol	Test conditions	Min	Typ	Max	Unit	
Reference input voltage (Fig.1)	V <sub>ref</sub>	V <sub>KA</sub> =V <sub>REF</sub> , I <sub>KA</sub> =10mA	2.475	2.5	2.525	V	
Deviation of reference input voltage over temperature (note) (Fig.1)	ΔV <sub>ref</sub> /ΔT	V <sub>KA</sub> =V <sub>REF</sub> , I <sub>KA</sub> =10mA T <sub>min</sub> ≤T <sub>a</sub> ≤T <sub>max</sub>		4.5	17	mV	
Ratio of change in reference input voltage to the change in cathode voltage (Fig.2)	ΔV <sub>ref</sub> /ΔV <sub>KA</sub>	I <sub>KA</sub> =10mA		ΔV <sub>KA</sub> =10V~V <sub>REF</sub>	-1.0	-2.7	mV/V
				ΔV <sub>KA</sub> =36V~10V	-0.5	-2.0	mV/V
Reference input current (Fig.2)	I <sub>ref</sub>	I <sub>KA</sub> =10mA, R <sub>1</sub> =10kΩ R <sub>2</sub> =∞		1.5	4	μA	
Deviation Of reference input current over full temperature range (Fig.2)	ΔI <sub>ref</sub> /ΔT	I <sub>KA</sub> =10mA, R <sub>1</sub> =10kΩ R <sub>2</sub> =∞ T <sub>a</sub> =full Temperature		0.4	1.2	μA	
Minimum cathode current for regulation (Fig.1)	I <sub>KA(min)</sub>	V <sub>KA</sub> =V <sub>REF</sub>		0.45	1.0	mA	
Off-state cathode Current (Fig.3)	I <sub>KA(OFF)</sub>	V <sub>KA</sub> =36V, V <sub>REF</sub> =0		0.05	1.0	μA	
Dynamic impedance	Z <sub>KA</sub>	V <sub>KA</sub> =V <sub>REF</sub> , I <sub>KA</sub> =1 to 100mA f≤1.0kHz		0.15	0.5	Ω	

note: T<sub>MIN</sub>=0°C, T<sub>MAX</sub>=+70°C

**CLASSIFICATION cZV<sub>ref</sub>**

<b>Rank</b>	*** 0.5%	.....1%
<b>Range</b>	2.487-2.513	2.475-2.525

**Figure 1. Test Circuit for V<sub>KA</sub> = V<sub>ref</sub>**

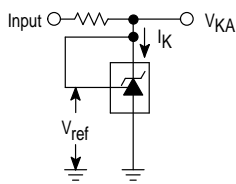

**Figure 2. Test Circuit for V<sub>KA</sub> > V<sub>ref</sub>**

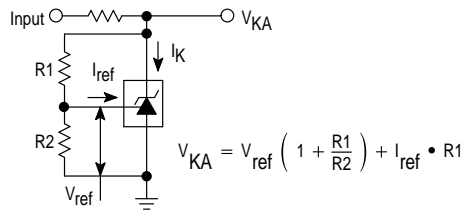

**Figure 3. Test Circuit for I<sub>off</sub>**

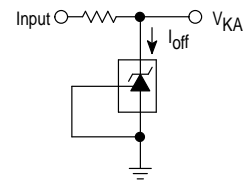

# Typical Characteristics

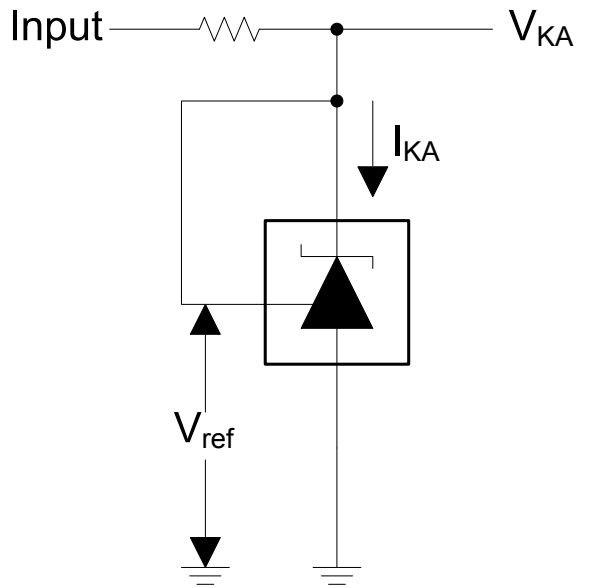
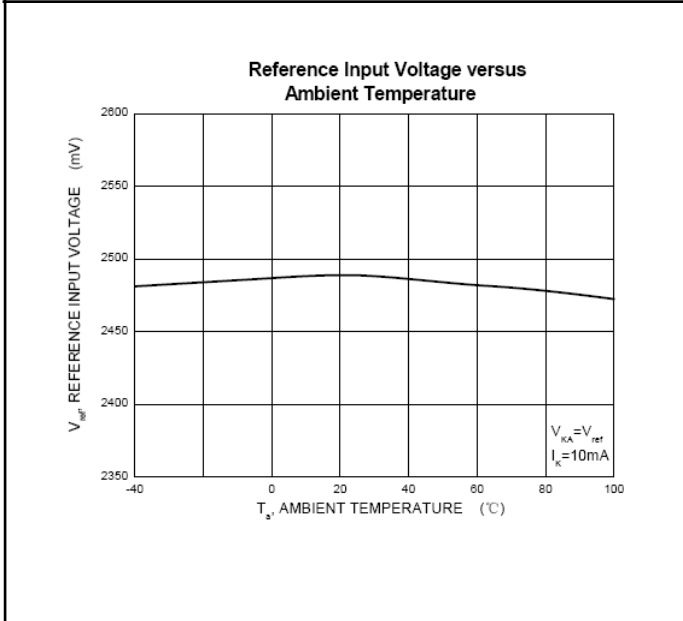
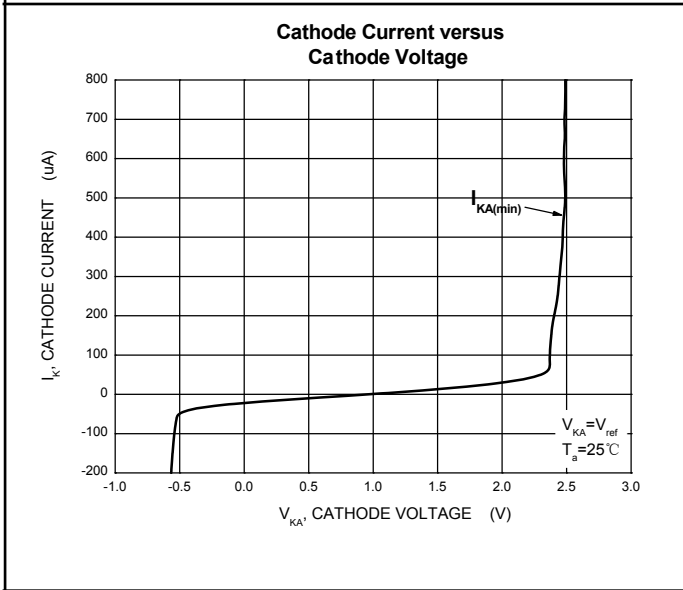
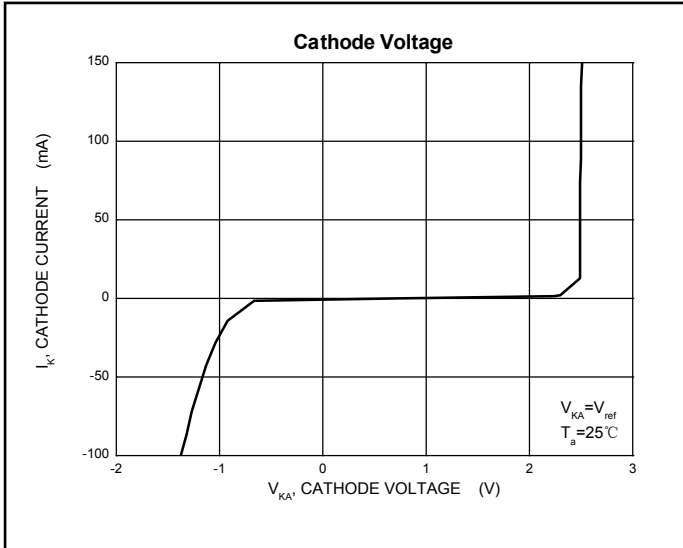

Test Circuit for  $V_{KA}=V_{ref}$

# Typical Characteristics

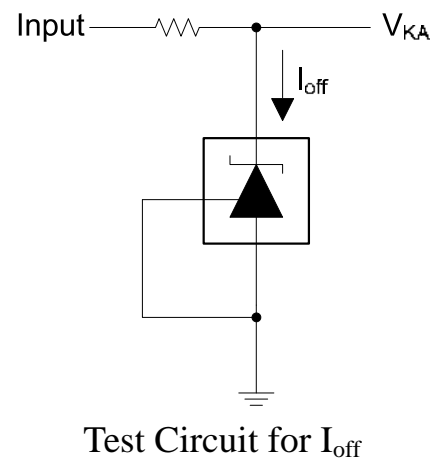
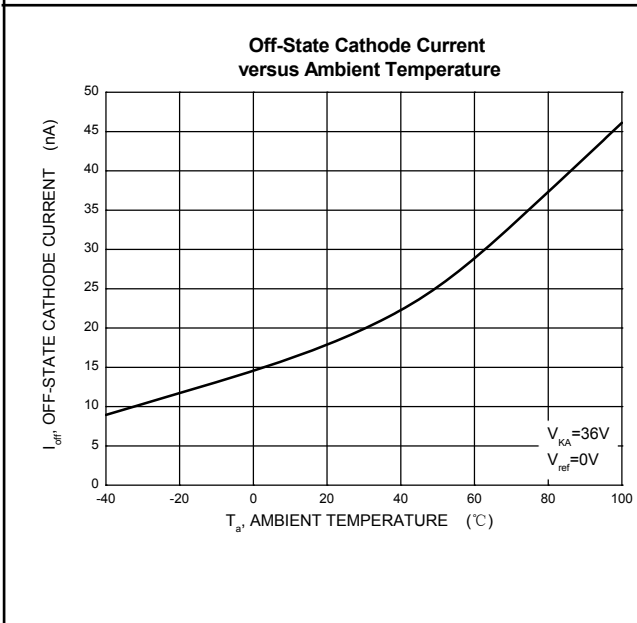
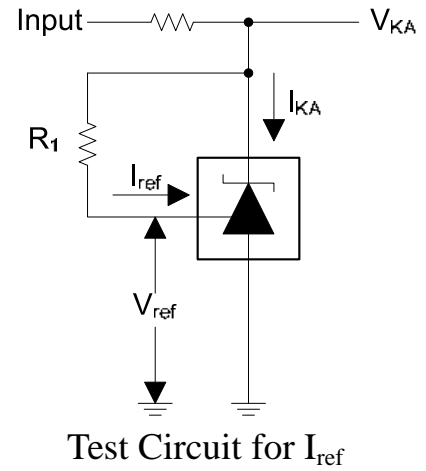
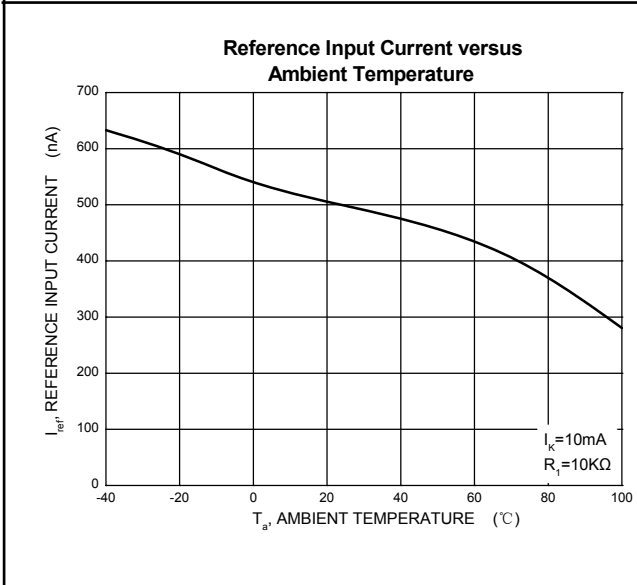
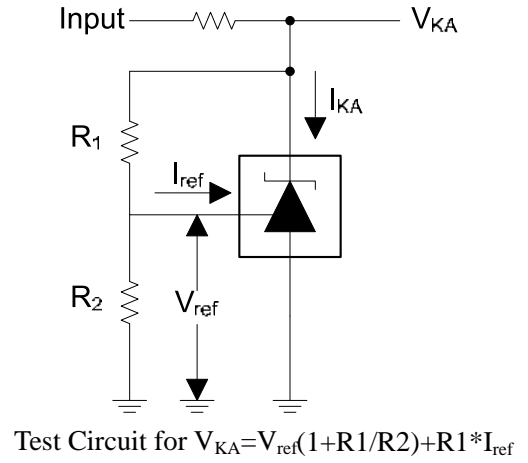
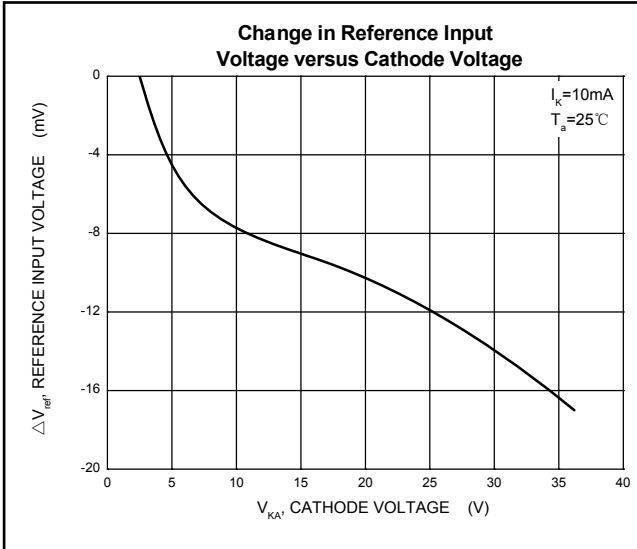

## SOT-23 Package Outline Dimensions

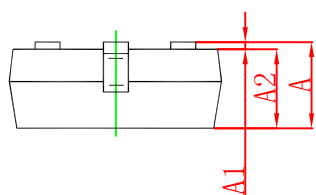
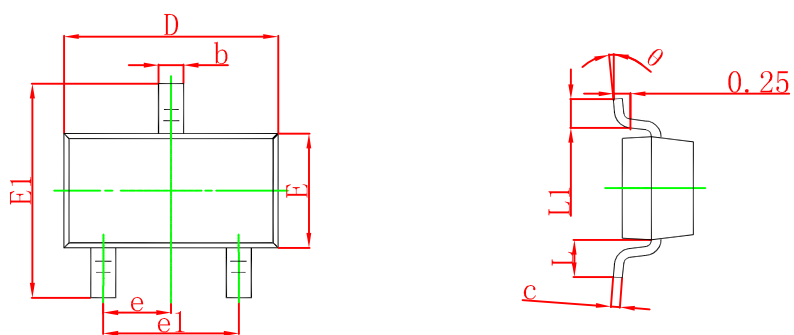

Symbol	Dimensions In Millimeters		Dimensions In Inches	
	Min	Max	Min	Max
A	0.900	1.150	0.035	0.045
A1	0.000	0.100	0.000	0.004
A2	0.900	1.050	0.035	0.041
b	0.300	0.500	0.012	0.020
c	0.080	0.150	0.003	0.006
D	2.800	3.000	0.110	0.118
E	1.200	1.400	0.047	0.055
E1	2.250	2.550	0.089	0.100
e	0.950 TYP		0.037 TYP	
e1	1.800	2.000	0.071	0.079
L	0.550 REF		0.022 REF	
L1	0.300	0.500	0.012	0.020
$\theta$	0°	8°	0°	6°

## SOT-23 Suggested Pad Layout

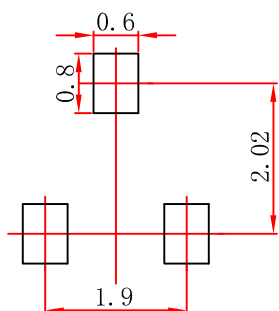

- Note:
1. Controlling dimension: in millimeters.
  2. General tolerance:  $\pm 0.05$  mm.
  3. The pad layout is for reference purposes only.

# SOT-23 Tape and Reel

## SOT-23 Embossed Carrier Tape

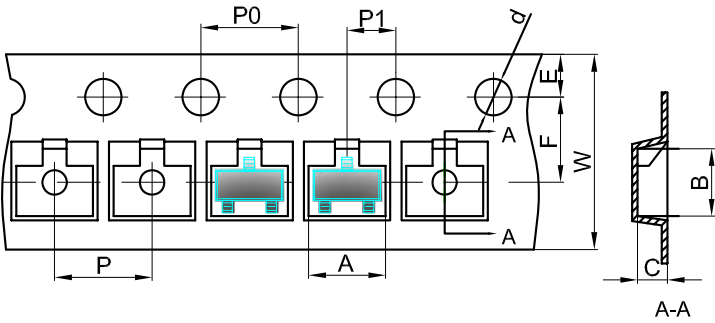

**Packaging Description:**  
 SOT-23 parts are shipped in tape. The carrier tape is made from a dissipative (carbon filled) polycarbonate resin. The cover tape is a multilayer film (Heat Activated Adhesive in nature) primarily composed of polyester film, adhesive layer, sealant, and anti-static sprayed agent. These reeled parts in standard option are shipped with 3,000 units per 7" or 17.8cm diameter reel. The reels are clear in color and is made of polystyrene plastic (anti-static coated).

Dimensions are in millimeter										
Pkg type	A	B	C	d	E	F	P0	P	P1	W
SOT-23	3.15	2.77	1.22	Ø1.50	1.75	3.50	4.00	4.00	2.00	8.00
(Tolerance)	+/-0.1	+/-0.1	+/-0.1	+/-0.1	+/-0.1	+/-0.1	+/-0.1	+/-0.1	+/-0.1	+0.3/-0.1

## SOT-23 Tape Leader and Trailer

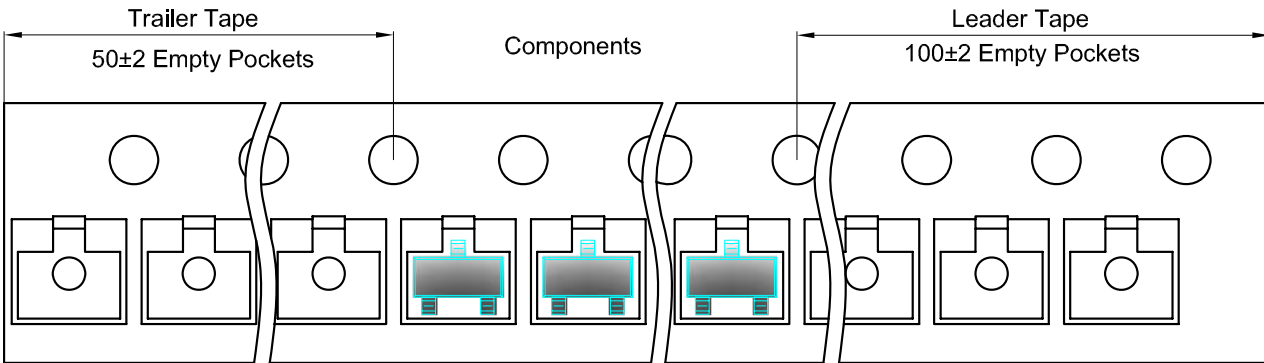

## SOT-23 Reel

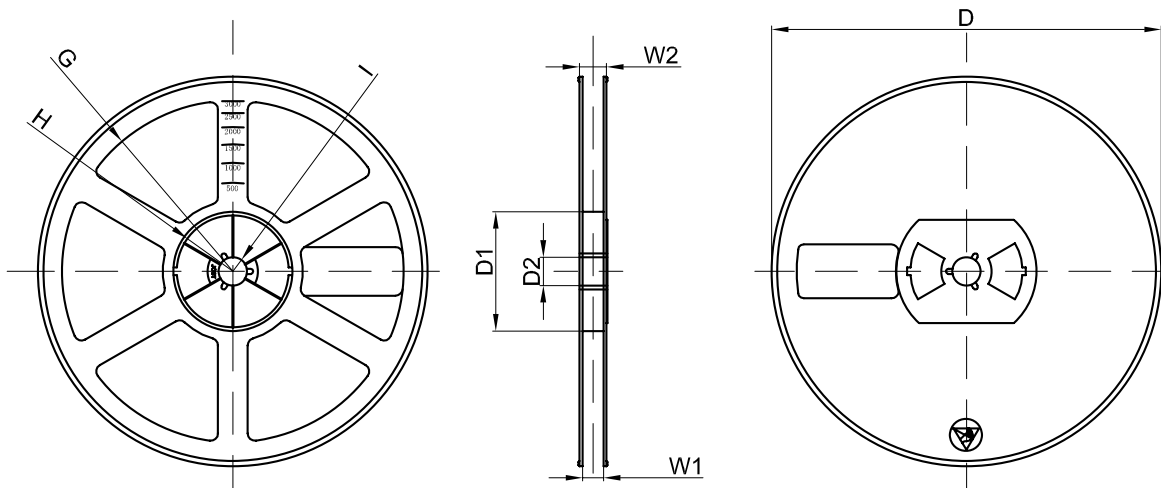

Dimensions are in millimeter								
Reel Option	D	D1	D2	G	H	I	W1	W2
7" Dia	Ø178.00	54.40	13.00	R78.00	R25.60	R6.50	9.50	12.30
Tolerance	+/-2	+/-1	+/-1	+/-1	+/-1	+/-1	+/-1	+/-1

REEL	Reel Size	Box	Box Size(mm)	Carton	Carton Size(mm)	G.W.(kg)
3000 pcs	7 inch	45,000 pcs	203×203×195	180,000 pcs	438×438×220	