

TO-92 Plastic-Encapsulate Transistors

3DD13002N46 TRANSISTOR (NPN)

FEATURE

- Lower Switching Applications

MAXIMUM RATINGS (T_a=25°C unless otherwise noted)

Symbol	Parameter	Value	Unit
V _{CB0}	Collector-Base Voltage	600	V
V _{CEO}	Collector-Emitter Voltage	100	V
V _{EBO}	Emitter-Base Voltage	6	V
I _C	Collector Current -Continuous	0.8	A
P _C	Collector Power Dissipation	0.8	W
R _{θJA}	Thermal Resistance from Junction to Ambient	156	°C/W
T _J	Junction Temperature	150	°C
T _{stg}	Storage Temperature	-55~150	°C

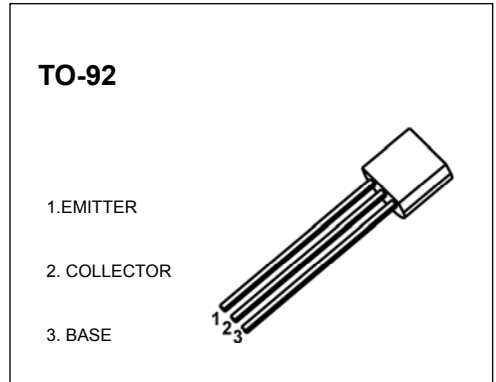

ELECTRICAL CHARACTERISTICS (T_a=25°C unless otherwise specified)

Parameter	Symbol	Test conditions	Min	Typ	Max	Unit
Collector-base breakdown voltage	V _{(BR)CBO}	I _C =100μA, I _E =0	600			V
Collector-emitter breakdown voltage	V _{(BR)CEO}	I _C =1mA, I _B =0	100			V
Emitter-base breakdown voltage	V _{(BR)EBO}	I _E =100μA, I _C =0	6			V
Collector cut-off current	I _{CBO}	V _{CB} =600V, I _E =0			100	μA
	I _{CEO}	V _{CE} =500V, I _B =0			100	μA
Emitter cut-off current	I _{EBO}	V _{EB} =6V, I _C =0			100	μA
Dc current gain	h _{FE1}	V _{CE} =10V, I _C =200mA	9		40	
	h _{FE2}	V _{CE} =10V, I _C =0.25mA	5			
Collector-emitter saturation voltage	V _{CE(sat)}	I _C =200mA, I _B =40mA			0.5	V
Base-emitter saturation voltage	V _{BE(sat)}	I _C =200mA, I _B =40mA			1.1	V
Transition frequency	f _T	V _{CE} =10V, I _C =100mA f=1MHz	5			MHz
Fall time	t _f	I _C =1A, I _{B1} =-I _{B2} =0.2A			0.5	μs
Storage time	t _s	V _{CC} =100V			2.5	μs

CLASSIFICATION OF h_{FE1}

Range	9-15	15-20	20-25	25-30	30-35	35-40